

165 - 170 lb. Suspended Washer-Extractor 42032 X7J, X7W

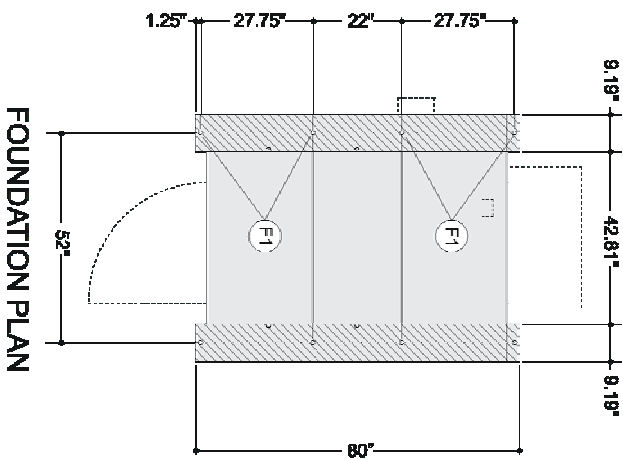
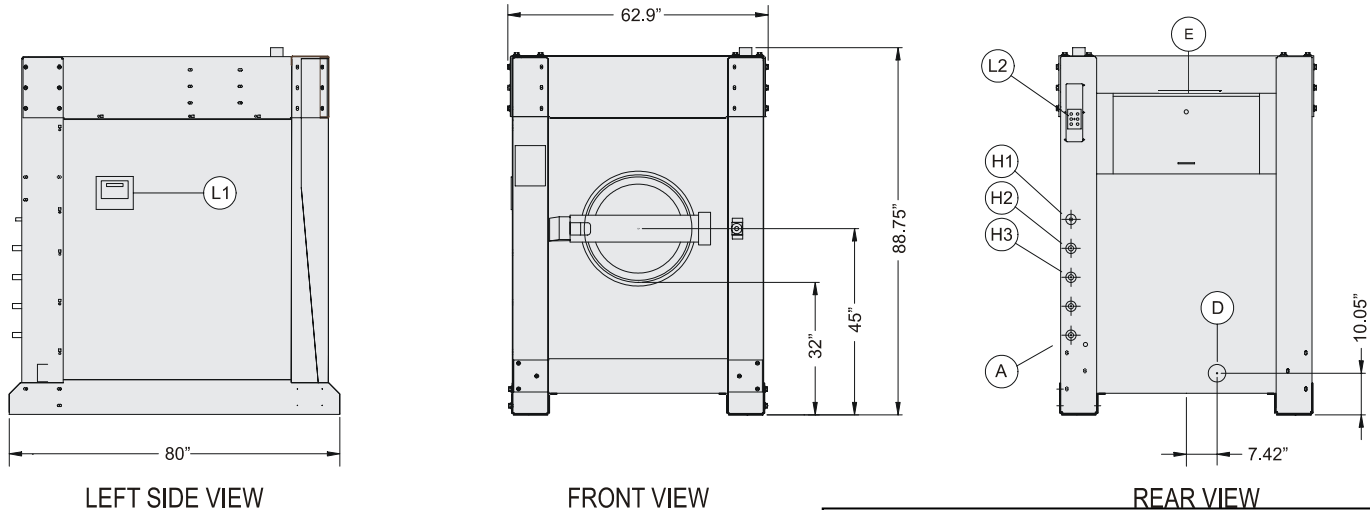

See dimensional drawing for fastening details. Consult Factory for foundation requirements.

Legend:

- A Compressed air inlet, 1/4"
- D Drain to sewer, 3"
- E1 Electrical connection
- F1 Anchor bolt holes, 1.0625" diameter
- H1 Hot water for supply, 3/4"
- H2 Hot water inlet, 1-1/4"
- H3 Cold water inlet, 1-1/4"
- L1 Soap chute
- L2 Liquid supply inlets

Specifications:

Maximum Capacity lbs (kg)	165 – 170 (75 – 77)
Wash Speed RPM	36-40
Distribution Speed RPM	60
High Speed Extract RPM	710
Final Extract G Forces	300
Approx. net weight lbs (kg)	5,400 (2468)

Features at a Glance:

- Single motor inverter drive
- Electrically-operated inlet valves and air-operated drain
- 15HP inverter – 6 Speeds
- Choice of E-P Plus microprocessors (J controller - 30 programmable formulas) or MARK V microprocessor (W controller – 100 formulas, 98 programmable)
- Suspension system
- Liquid soap connectors standard (six on X8J, twelve on X8W)
- Triple water seals protect bearings
- Ideal for laundering delicates
- 5-year limited warranty on frame, cylinder, and shell
- 3-year limited warranty on non-wearable parts

ELECTRICAL SPECIFICATIONS					
Voltage	Running Amps	Phase	Frequency	Fuse (Amps)	Circuit Breaker (Amps)
208	40	3	60	FRN50	50
380	23	3	50	FRS30	30
380	23	3	60	FRS30	30
600-480	19	3	60	FRS25	25

See Fuse and Wire Size manual MAEFUSE1AE for safety information.

Pellerin Milnor Corporation, P.O. Box 400, Kenner, LA 70063 ph: 504-467-9591, fx: 504-468-3094
<http://www.milnor.com> e-mail: mktg@milnor.com